

# *Mailbox Installation Standards*

## General Location:

Whenever possible, your mailbox should be located after your driveway opening. This location placement improves visibility, minimizes the amount of snow that comes off of the snow plow, and improves the approach for your mail carrier. The diagram below further clarifies this preferred placement:

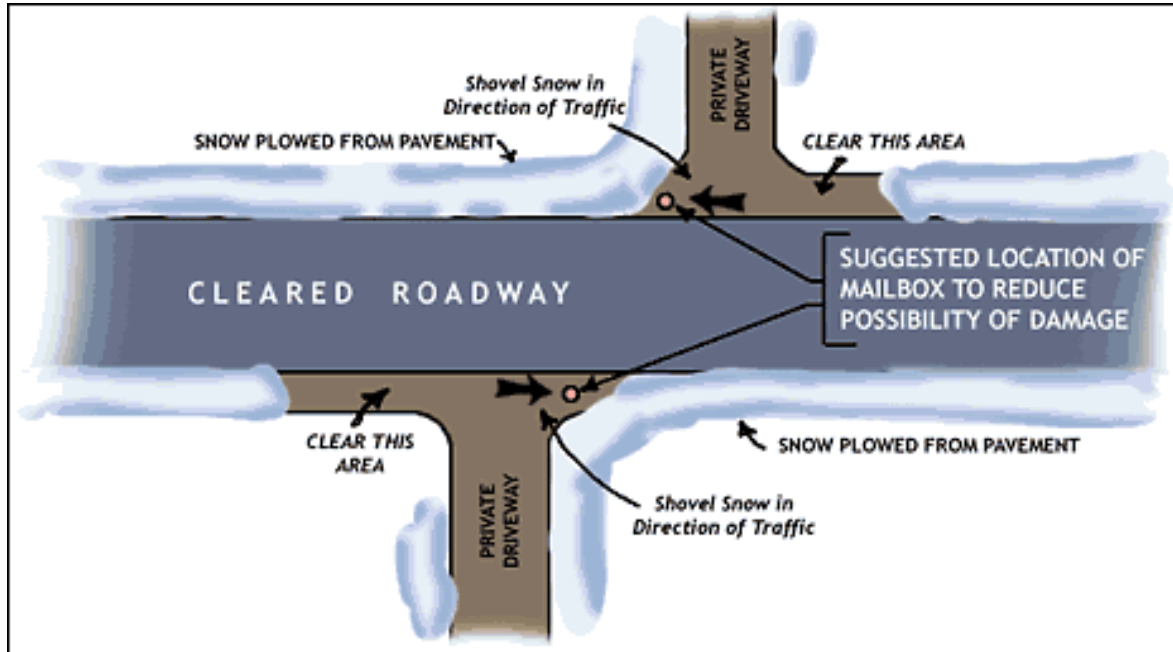

## Mailbox Support Design:

In many cases, it is best to use an extended arm type of post with a free-swinging suspended mailbox. This allows snowplows to sweep near or under boxes without damage to supports and provides easy access to the boxes by carrier and customers. The following picture shows a free-swinging suspended mailbox:



In addition, note the strategic placement of the red reflector on the point closest to the road. This will help your local snowfighter see and avoid your mailbox during winter storms.

**Offset:**

Mailboxes should be set back from the edge of the shoulder – regardless of whether the shoulder is gravel or paved. In other words, the face of the mailbox should be at least **one foot (1')** back from the edge of the normally plowed surface of the highway or the face of curb. Greater offset distances are encouraged whenever possible to allow the mail carrier to get further out of traffic and to further minimize potential damage to your mailbox. The following picture shows a mailbox with a reasonable offset:



Mailboxes in sidewalk areas should leave at least 36" behind the back of the box or the post, whichever is located the furthest from the road.



**Height:**

According to USPS standards, a mailbox must be installed with the bottom of the mailbox located between 41” and 45” high above the surface of the highway shoulder. MaineDOT recommends that this height be closer to the 45” measurement to minimize conflict with the height of the plow truck wing when snow is being pushed back during, or between, winter storms. The following picture further clarifies the height considerations:



**Post Size, Type and Embedment:**

Mailbox posts must be sturdy enough to hold up the mailbox in all types of weather conditions, however they cannot be so rugged that they present a hazard to vehicles that inadvertently leave the road. If a mailbox support is struck by a vehicle, it must easily break away. Therefore, the following types of posts are deemed acceptable:

- **4” x 4” wooden posts** embedded **2 feet** into the ground. Larger wooden posts (4” x 6” or 6” x 6”) may be used only if the post is drilled through with an appropriate spade bit to create a shear plane. The following diagram indicates the necessary holes and spacing.

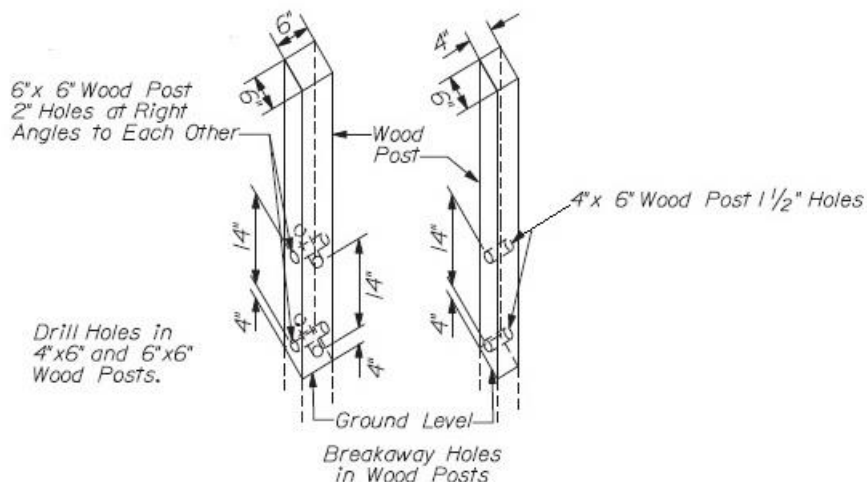

- 1” to 2” round diameter steel or aluminum pipe or standard U-channel post embedded 2 feet into the ground.
- Unacceptable mailbox supports include: anything that is filled with concrete, masonry and stone structures, heavy steel structures, and most objects that were intended for other uses (e.g. antique plows, I-beams, and various other household tools and objects).

**NOTICE: Mailboxes, attachments or support systems not consistent with this policy are considered “Deadly Fixed Objects” (aka. “DFOs”) and are in violation of 23 MRSA §1401-A.**